

DESCRIPTION

The LT-HST Tee Splice Kit is for use with braided versions of Nelson Heat Tracing Systems' type HLT heater cables in ordinary and hazardous areas.

KIT CONTENTS

- 5 Wire Ties
- 2 Tubes of Silicone
- 5 Uninsulated Splice Connectors
- 10 Insulated Splice Connectors
- 5 Shrink Tubes, 13mm (0.5") diameter, 152mm (6") length

STRIPPING PROCEDURES

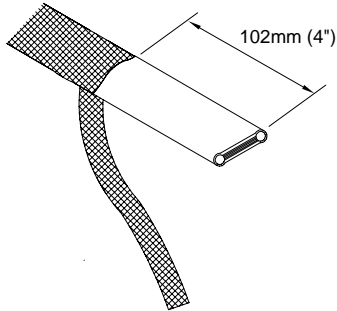

- 1 Unravel approximately 102mm (4") of braid to form a ground strap.

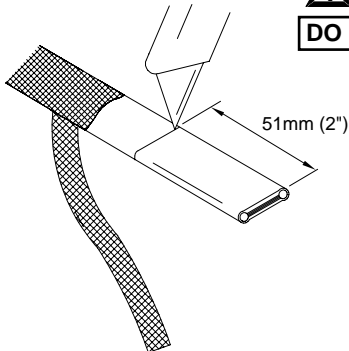

- 2 Lightly cut around heater outer jacket 51mm (2") from the end. Lightly cut the outer jacket up the center between the first cut mark & the cable end. Bend cable to break outer jacket.

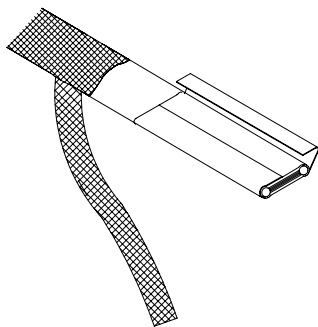

- 3 Remove jacket from the heater cable.

⚠ WARNING:
DO NOT CUT BUS WIRES

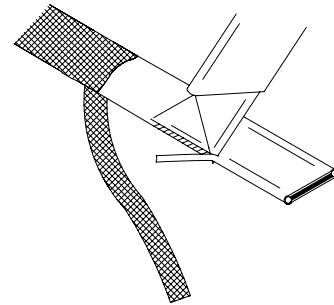

- 4 Shave core material from the outside of each bus wire.

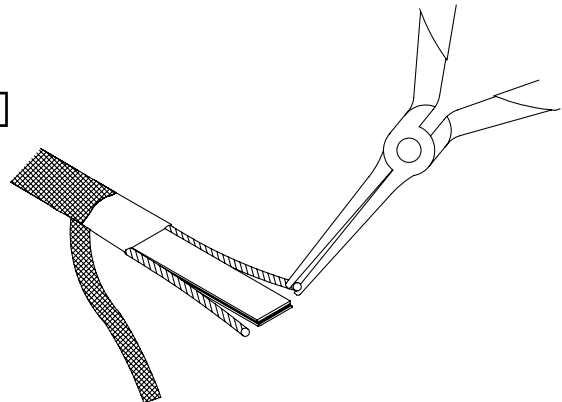

- 5 Starting at the end, pull each bus wire away from the core material and remove exposed core material.

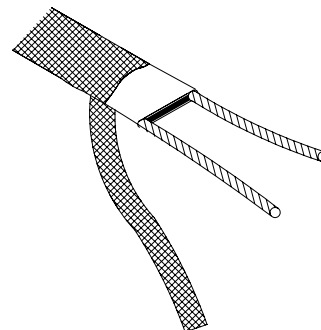

- 7 Repeat steps 1-5 for all heater cables.
8 Proceed to "Shrink Tube Procedures", sheet 2.

SHRINK TUBE PROCEDURES

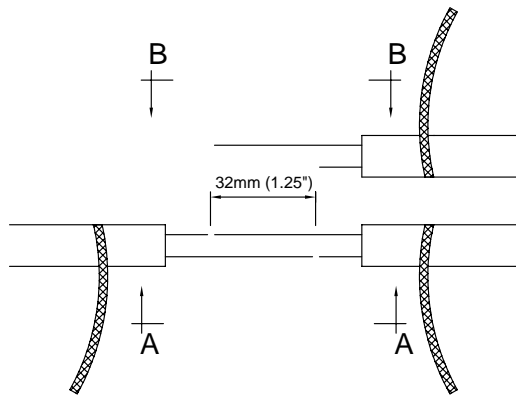

- 1 Position three heater cables with the ground braid on the same side. Remove 32mm (1.25") of bus wire from each heater cable to offset for the insulated splice connectors.

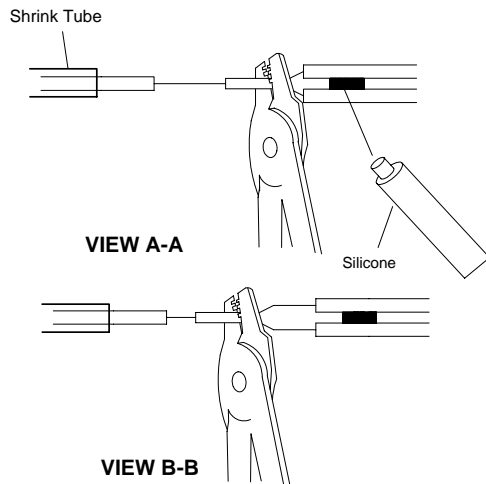

- 2 Slide a shrink tube over the single heater cable side. Twist bus wires together from the two heater cables and crimp into insulated splice connectors, then connect to the single heater cable.
- 3 Inject a generous amount of silicone between the two heater cables forming a moisture barrier.

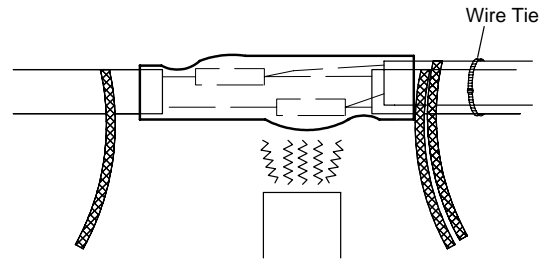

- 4 Center the shrink tube over the connectors leaving the braid straps exposed. Shrink with heat gun until completely shrunk. A uniform bead of glue should appear around the ends of the shrink tube.
- 5 Fasten a wire tie around the two heater cables to hold in place.

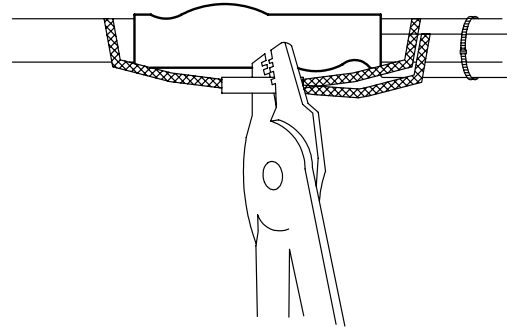

- 6 If necessary, cut excess length from braid straps. Crimp the braid straps together into an insulated splice connector. Secure connector at the indented area with one and a half wraps of fiberglass tape (*not included in kit*).

Nelson Heat Tracing Systems products are supplied with a limited warranty. Complete Terms and Conditions may be found on Nelson's website at www.nelsonheaters.com.